

INSTRUCTIONS

1. Prepare the wall to accommodate the fitting (A) as shown in Fig.1, ensuring there is a hole for the passage on the left. The arrow sticker (B) inside the frame must be pointed upwards. Add cement, ensuring fitting is level.
2. Open the optical unit (C) holding the cover (D) against the die-cast body (E). Remove the two screws holding the cover onto the frame. To facilitate installation disconnect the earth-wire (H) as shown in Fig.3. Remove the sachet (W).
3. Wire the fitting ensuring correct polarity at the power terminal. Cover the line and neutral conductor cables (N) with two glass silicon sheaths (K). Secure the lines together, as in Fig. 4.
4. Fit the die-cast body (E) into the frame (A) as shown in Fig.5. ATTENTION: Fitting the body should allow for the bulb holder to be up on the right (P). The arrow sticker (Q) inside the body should point upwards.
5. Connect the earth wires (H) by tightening screws on the cover (D), placing the washer between the cable and eyelet, as shown in Fig.7. Close the optical unit, and tighten the screws that hold the cover against the body.

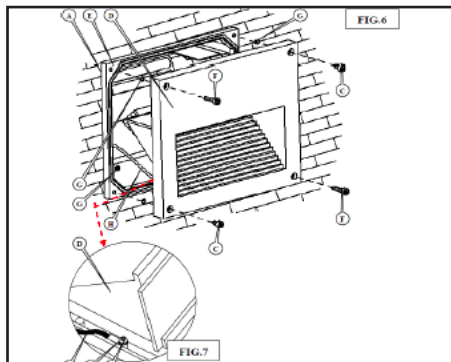
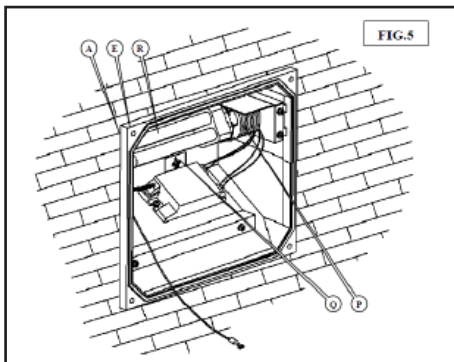
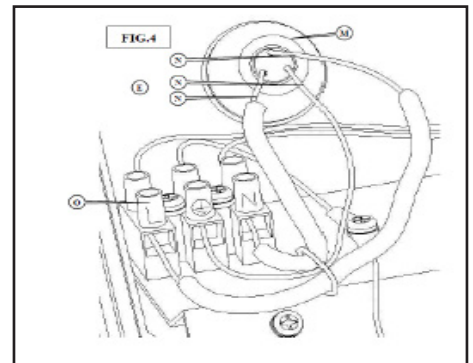
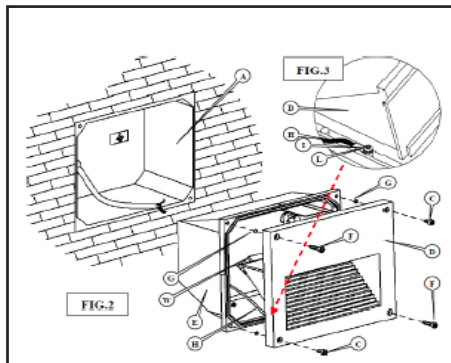
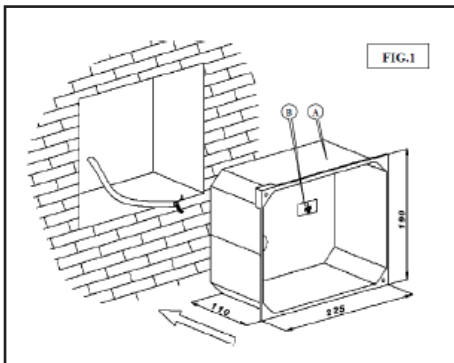

IMPORTANT WARNINGS

Do not install the luminaire in areas without sufficient air circulation. The manufacturer cannot be considered liable for any damage caused by inappropriate use of the luminaire other than its manufactured purpose.

Luminaries must be installed by a qualified registered electrician only. Any misuse of the luminaire when power is activated may cause the risk of an electric shock.

The manufacturer does not accept any responsibility of any issues resulting from the non-compliance of the recommendations included in this instruction document. These instructions are issued as a guide to assist the installer to satisfactory conclusion.

The manufacturer reserves the right to change the design of this product without prior notice.

WASTE DIRECTIVE

The European Directive 2002/96/EC on waste electrical and electronic equipment requires that electric and electronic devices must not be disposed of in the normal household waste. For correct disposal, please use authorized waste disposal facilities or return to the distributor at the date a new lighting fitting is purchased. Lamps, if disposed together with the lighting fitting, should not be broken up as they contain pollutants, which are harmful to the environment. Unauthorized disposal of the foregoing waste material is punishable by law.

