

Length (L)	Width (W)	Height (H)	Mounting Kit	Weight
615	98	84	110-370	0.9Kg
1175	98	84	700-960	1.7Kg
1455	98	84	970-1230	2Kg
615	145	100	475	1.7Kg
1175	145	100	700	3Kg
1455	145	100	940	3.9Kg

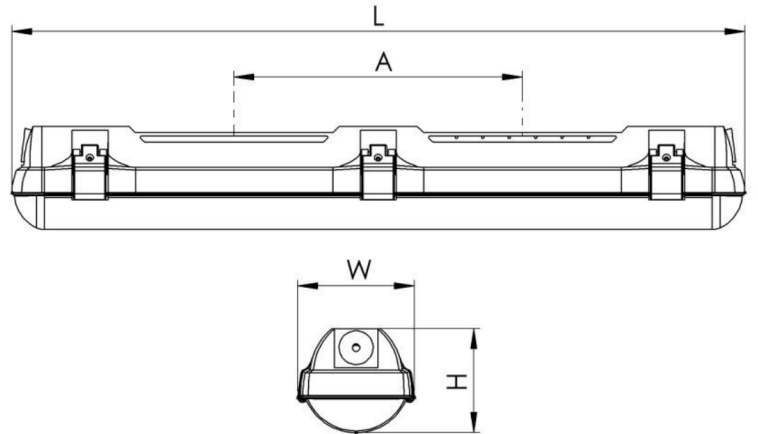

The installation kit supplied with the luminaire does not include anchors for ceiling installation.

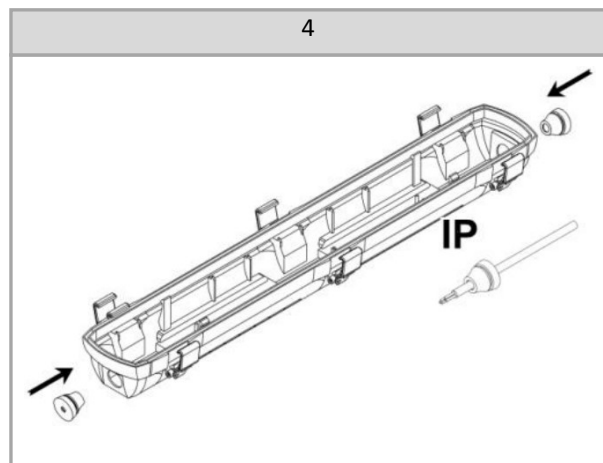

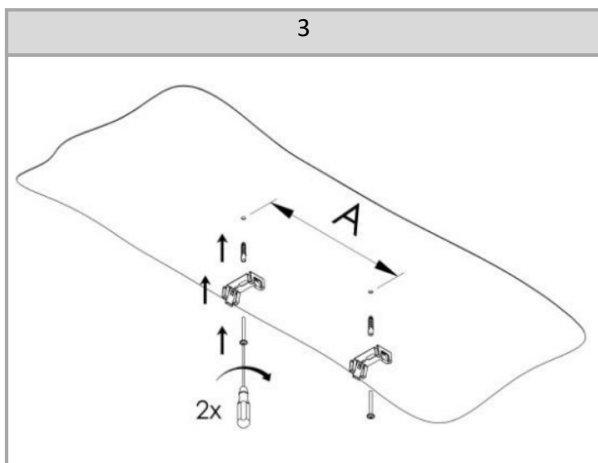
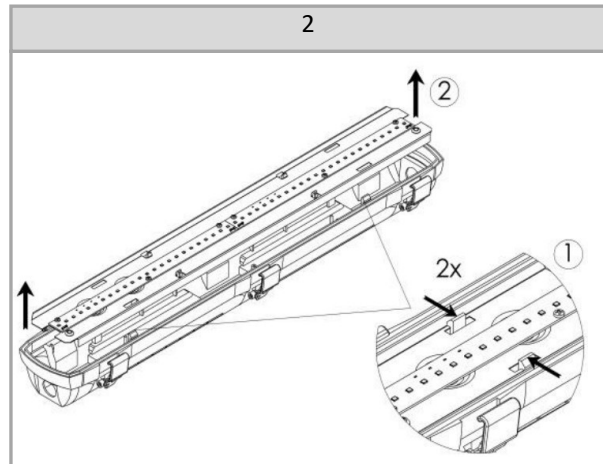
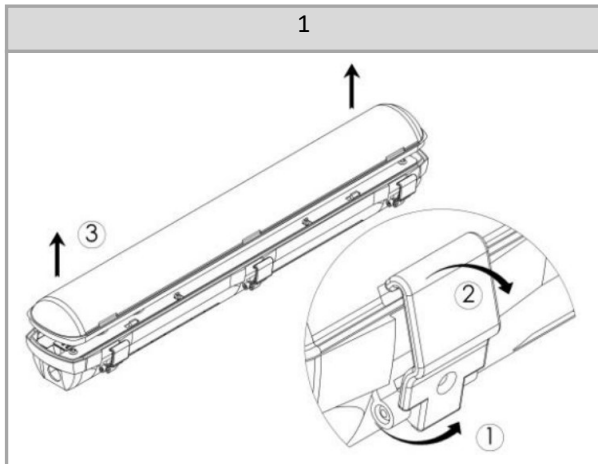
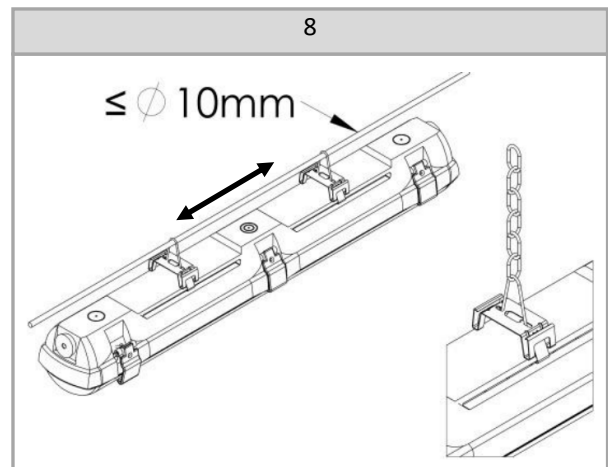
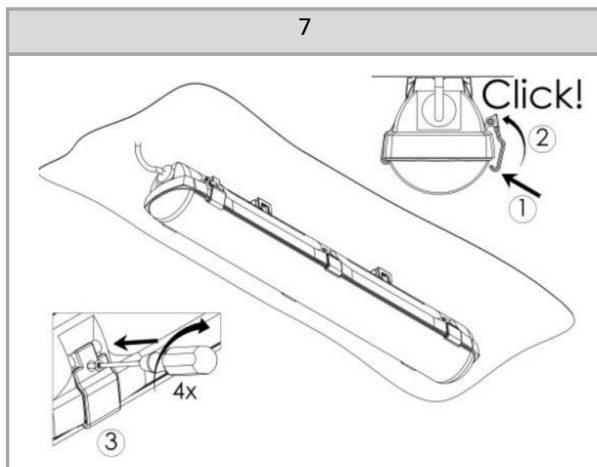
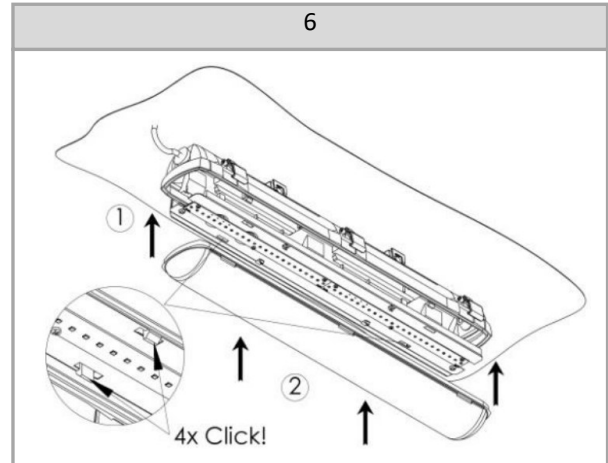
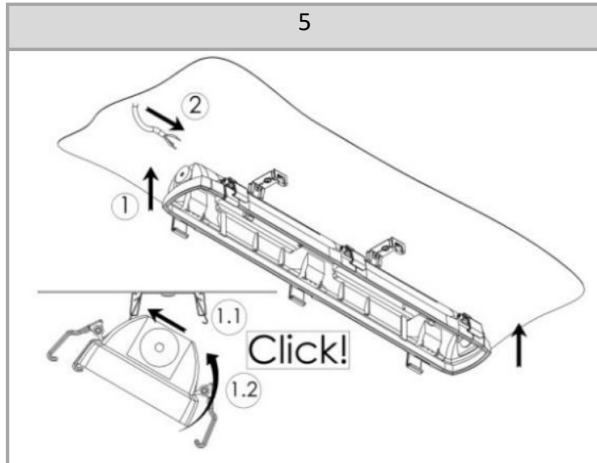

IMPORTANT WARNINGS

Do not install the luminaire in areas without sufficient air circulation. The manufacturer cannot be considered liable for any damage caused by inappropriate use of the luminaire other than its manufactured purpose. Luminaires must be installed by a qualified registered electrician only. Any misuse of the luminaire when power is activated may cause the risk of an electric shock.

The manufacturer does not accept any responsibility of any issues resulting from the non-compliance of the recommendations included in this instruction document. These instructions are issued as a guide to assist the installer to satisfactory conclusion. The manufacturer reserves the right to change the design of this product without prior notice.

WASTE DIRECTIVE

The European Directive 2002/96/EC on waste electrical and electronic equipment requires that electric and electronic devices must not be disposed of in the normal household waste. For correct disposal, please use authorised waste disposal facilities or return to the distributor at the date a new lighting fitting is purchased. Lamps, if disposed together with the lighting fitting, should not be broken up as they contain pollutants, which are harmful to the environment. Unauthorised disposal of the foregoing waste material is punishable by law.

