

EM3H SURFACE/WALL

IP20 CLASS II CE

FEATURES & BENEFITS

- > Surface ceiling or wall mounted luminaire
- > 3hr maintained/non-maintained operation
- > Attractive slim design
- > Screen printed panel to ensure uniform illumination of legend
- > Quick and easy installation with a fixing plate
- > 25 or 30 metre sign viewing distance
- > Fully compliant with EN60598.2.22



PERFORMANCE

Light source	LED (x14)
Supply power	2.6W (25m version), 3.1W (30m version)
Charge power	0.8W typically
Colour temperature	5000K
Battery	3.6V 900mAh NiCd
Legend	EC & ISO format right/left/down/up supplied

MATERIALS

Body	Polycarbonate
Finish	White
Mounting	Surface (wall or ceiling) via mounting plate
Wiring	Top and rear cable entry

OPTIONS

- > Automatic self-test in accordance with BSEN62034
- > DALI
- > Flag pole mounting bracket allowing the housing to be mounted at 90 degrees to the wall
- > Central battery functionality

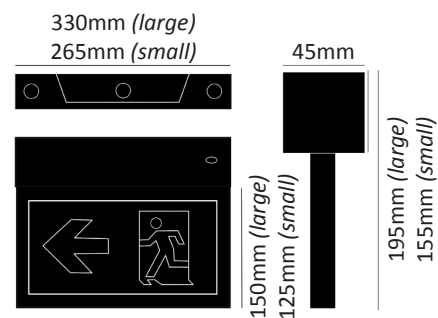

LAMP	VIEWING DISTANCE	DIMENSIONS	STANDARD	DALI
2.6W	25m	265 x 155	83400105	N/A
3.1W	30m	330 x 195	83400205	83400203