

EM3H SUSPENDED LED

IP20 CLASS I CE

FEATURES & BENEFITS

- > High efficiency LED light source
- > 3hr maintained/non-maintained operation
- > Attractive slim design
- > Screen printed panel to ensure uniform illumination of legend
- > Quick and easy installation with a fixing plate
- > 25 or 30 metre sign viewing distance
- > Simple height adjustment with two locking clutch bush mechanisms
- > Fully compliant with EN60598.2.22

PERFORMANCE

Light source	LED (x14)
Supply power	2.6W (25m version), 3.1W (30m version)
Charge power	0.8W typically
Colour temperature	5000K
Battery	3.6V 900mAh NiCd
Legend	EC & ISO format right/left/down/up supplied

MATERIALS

Body	Polycarbonate
Finish	White
Mounting	Suspension wires (15-1000mm adjustment)
Wiring	Top and rear cable entry

OPTIONS

- > Automatic self-test in accordance with BSEN62034
- > DALI
- > Central battery functionality

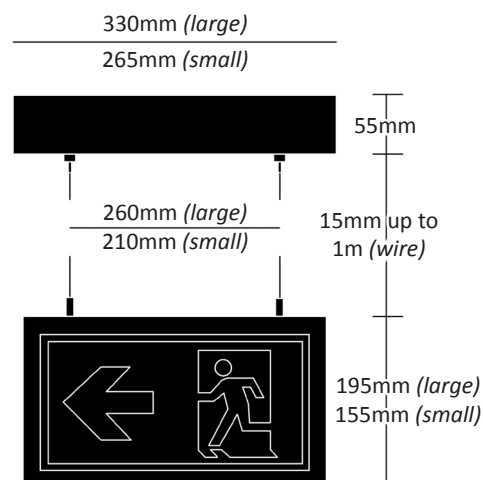

LAMP	VIEWING DISTANCE	DIMENSIONS	STANDARD	DALI
2.6W	25m	265 x 155	83500105	N/A
3.1W	30m	330 x 195	83500205	83500203