

MONARCH LED

IP65 IK07 CLASS I CE

A high efficiency, lightweight, suspended or surface-mounted IP65 industrial hi-bay LED luminaire. Ideal for the illumination of warehouses, industrial units and sports facilities.

FEATURES & BENEFITS

- > High resistance to chemical and atmospheric agents
- > Deep cooling fins for effective thermal management
- > Short circuit and surge protection
- > Long rated LED life $\geq 108,000$ hrs (L80/B20) @25°C
- > Optimum colour consistency—3 step MacAdam ellipse tolerance
- > Photobiological safety: RG0

PERFORMANCE

Light source	LED (Samsung)
LED output	15360 - 33770lm
Luminaire output	14454 - 31778lm
Luminaire efficiency	>151lm/W
CRI	>80
Beam angle	90°

MATERIALS

Body	Die-cast aluminium
Finish	Anthracite grey (RAL 7039)
Optics	PMMA satin anti-UV clusters
Mounting	Steel eye bolt M6 / Ceiling or wall rotation bracket

OPTIONS

- > 3hr emergency
- > Clear 4mm tempered glass
- > IK10 protection grid
- > 60 degree beam
- > Motion sensor
- > Other colour temperatures on request

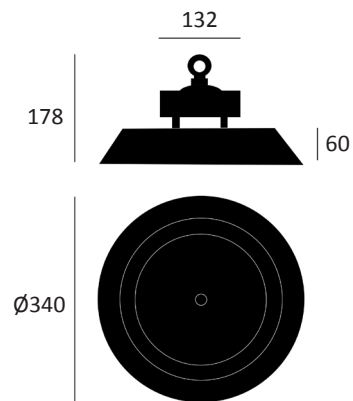

LAMP	COLOUR TEMP	DELIVERED LUMENS	SUSPENDED STANDARD	SUSPENDED DALI	SURFACE STANDARD	SURFACE DALI
87W	4000K	14454lm	65700101	65700103	65700501	65700503
136W	4000K	21055lm	65700201	65700203	65700601	65700603
177W	4000K	29002lm	65700301	65700303	65700701	65700703
210W	4000K	31778lm	65700401	65700403	65700801	65700803