

628
450W (H1)

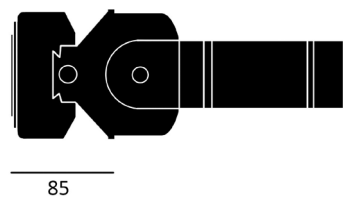

320

130



85

275

75W

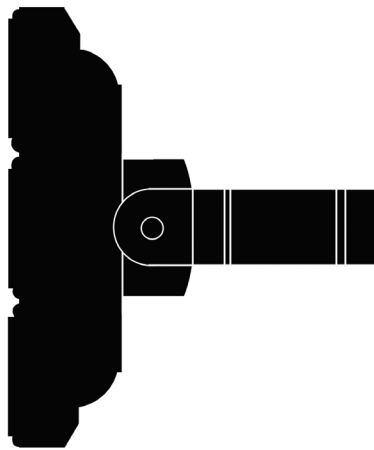

85 (L1)

275 (L2)



power	H1	H2	L1	L2	D1	D2	D3	W1	R	Ø
75W	320	130	85	225	40	48	/	55	6.5	13
150W	320	215	85	275	40	48	/	55	6.5	13
230W	320	324	85	275	40	48	/	55	6.5	13
300W	320	433	85	275	40	48	/	55	6.5	13
450W	628	324	85	275	40	50	60	55	6.5	13
600W	628	433	85	275	40	50	60	55	6.5	13
900W	628	690	85	390	40	50	60	55	6.5	13
1200W	628	910	85	390	40	50	60	55	6.5	13

INSTRUCTIONS

1. Open the box and check your product. In case of damage contact Spear Lighting.
2. Fasten the brackets on the wall/surface with stainless steel screws.
3. Adjust the floodlight to direct the light in desired direction before tightening the screws.
4. Be sure to connect the wires correctly. Brown - live, blue - null, yellow/green - grounding.
Make sure the power cord was fixed for anti-pull purpose, and the connection is waterproof in outdoor application. NOTE: The external flexible cable of this luminaire cannot be replaced.
5. Switch the voltage on and check the see that the floodlight works properly.

This modular floodlight can be installed on wall, ceiling or a horizontal surface.

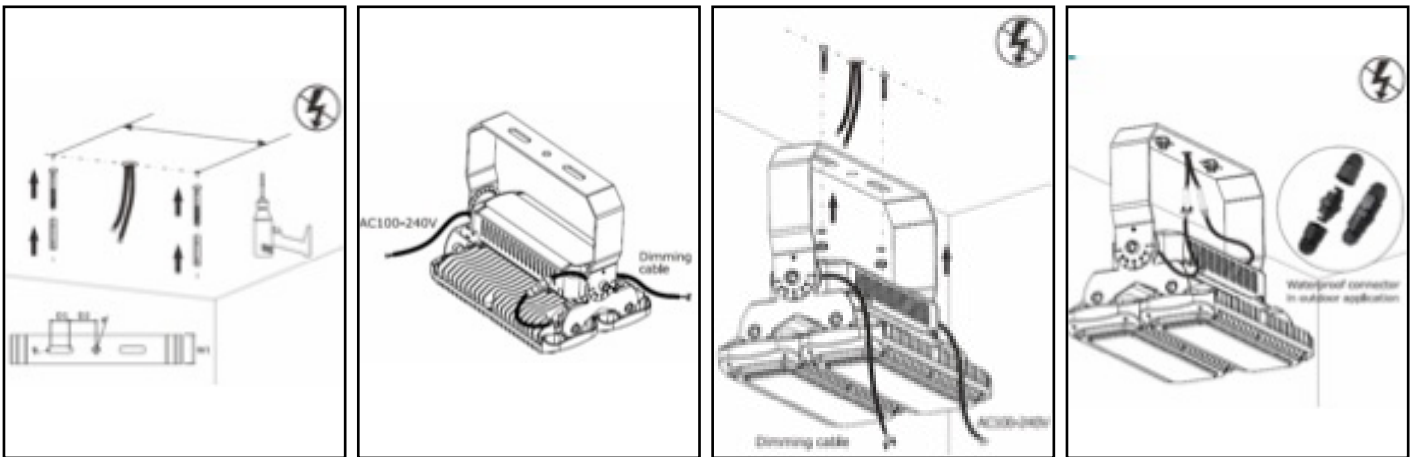

IMPORTANT WARNINGS

Do not install the luminaire in areas without sufficient air circulation. The manufacturer cannot be considered liable for any damage caused by inappropriate use of the luminaire other than its manufactured purpose.
Luminaries must be installed by a qualified registered electrician only. Any misuse of the luminaire when power is activated may cause the risk of an electric shock.
The manufacturer does not accept any responsibility of any issues resulting from the non-compliance of the recommendations included in this instruction document. These instructions are issued as a guide to assist the installer to satisfactory conclusion.
The manufacturer reserves the right to change the design of this product without prior notice.

WASTE DIRECTIVE

The European Directive 2002/96/EC on waste electrical and electronic equipment requires that electric and electronic devices must not be disposed of in the normal household waste. For correct disposal, please use authorized waste disposal facilities or return to the distributor at the date a new lighting fitting is purchased. Lamps, if disposed together with the lighting fitting, should not be broken up as they contain pollutants, which are harmful to the environment. Unauthorized disposal of the foregoing waste material is punishable by law.

